

# Two Piece Top Entry Ball Valves



SEVERE SERVICE ENGINEERING

## Model: TE-2

TRUNNION MOUNTED  
BI-DIRECTIONAL SHUT-OFF

Sizes: 1/2" to 16"  
1-13/16" to 9" +

Pressure Class: ANSI / ASME 150 - 4500  
B16.34, API 6A, API 6D, BPVC  
API 2000 - 15000

Temperature: -320° F (Cryogenic) to (+) 1500 ° F  
(High temperature)

End Connections: RF / RTJ / WELD END / HUB END  
Special ANSI B16.5 / API 6A / ANSI B16.25

Leakage Class: -BUBBLE-TIGHT (Soft-Seated)  
-ANSI/FCI 70.2 - Class V & VI (Metal Seated)  
-API 6D & API 6A - PSL1-3  
-API 598, 150, 5208 RATE

Actuation: Manual, Pneumatic, Hydraulic, Electric...



## Standard Features

1. Metal-to-metal body/bonnet seal: reliable and fire safe
2. Solid one-piece ball, stem trunnion designs: Stronger, simpler, and more accurate
3. Pre-loaded, pressure assisted seating, bi-directional seating: no lateral ball movement along flow bore. Pre-loading provides uniform torque. Pressure assistance assures tighter seal.
4. Engineered stem and seat seals per customer specification
5. Rigid bolted body: optimal strength and versatility
6. Trunnion bearing supports: assures alignment and reduce ball/seat torque

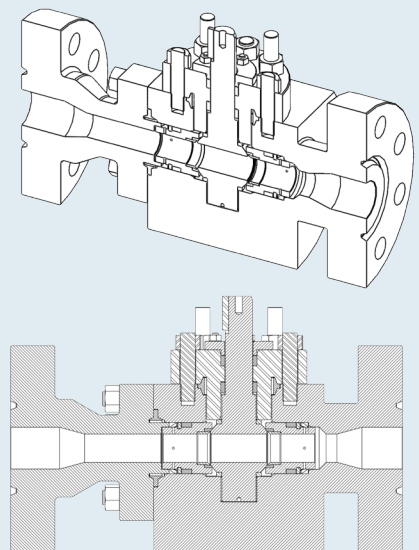

13124 Trinity Drive, Stafford, TX. 77477  
www.cornerstonevalve.com  
(281) 880-8188



# Model: TE-2

## PARTS LIST

A/R = AS REQUIRED

ITEM	QTY	DESCRIPTION
1	1	Body
2	1	Bonnet
3	1	Ball
4	1	Tail Piece
5	2	Seat
6	2	Seat Seal
7	2	Seat Retainer
8	2	Piston Seal
9	2	Pusher Ring
10	2	Wave Spring
11	1	Bonnet Seal
12	1	Bearing
13	1	Thrust Bearing
14	1	Spacer Ring
15	2	Stem Seal
16	[A/R]	Packing Flange
17	1	Bleed Fitting
18	[A/R]	Bonnet Studs
19	[A/R]	Bonnet Nuts
20	[A/R]	Packing Studs
21	[A/R]	Packing Nuts
22	[A/R]	Body Studs
23	[A/R]	Body Nuts
24	1	Body Seal

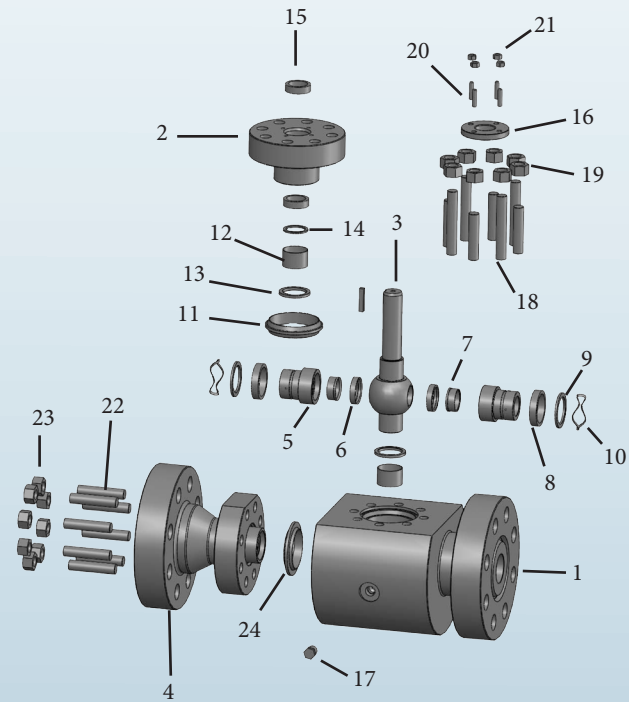

CORNERSTONE VALVE  
CAN ASSIST IN  
SELECTION OF THE  
OPTIMUM MATERIALS FOR  
YOUR SPECIFIC SERVICE.

## Available Options

- Solids proof design
- Double block & bleed
- Steam purge ports
- Secondary & tertiary stem seals
- Soft seated or metal seated
- Various ball coatings
- CRA overlays
- Firesafe
- Subsea
- Materials to nace standards
- More available upon request

## Applications

- Oil & Gas production natural gas to 15,000 PSIG
- Crude Oil
- Ore slurries
- Steam & Condensate
- Cryogenic / Liquid or Gas
- Subsea

## Materials

Carbon Steel, Stainless Steel, Duplex, Stainless, Chrome Molybdeum, Nickel & Titanium based alloys and other exotic alloy available upon request.

